

Boating Hacks: A Kayak Work Stand

Introduction



If you own one or more kayaks, eventually you will need to do some amount of cleaning and maintenance. I have found it is a lot easier to work on my kayaks if they're at chest height. So, a work stand becomes a useful kayak accessory.

I decided to design and build my own work stand.

This is a parts list and instructions for building a kayak work stand specifically designed for inflatables. The cost is about \$120 for materials (2023 prices) if you need to buy everything. I already had some materials laying around my shop as scrap. Commercial two-piece kayak stands start at about \$65, but do not work well for inflatable kayaks as they sag in the middle without proper support.

Assembly should take about two hours once you have collected all the parts.

Contents

| | |
|--|---|
| Introduction..... | 1 |
| Boating Hacks: A Kayak Work Stand..... | 1 |
| Design Constraints..... | 2 |
| Design Notes..... | 2 |
| Layout..... | 4 |
| Pivot Bolts..... | 5 |
| Nylon Straps..... | 5 |
| Tools..... | 7 |
| Materials..... | 7 |
| Assembly..... | 9 |

Figures and Illustrations

Boating Hacks: A Kayak Work Stand

Design Constraints

I wanted a simple, inexpensive kayak stand suitable for the boats I own. I have two inflatables and one hardshell, and my hardshell is the heaviest at 47 pounds. So, the stand needed to support at least 50 pounds and provide support across the length of the boats, not just at each end. The work stand needed to fold up when not actually in use. I also needed my stand to be weatherproof, as I expected to be storing it outside and did not want it rotting away. Finally, I wanted it simple to build.

After browsing YouTube channels for ideas, I came up with a design made of PVC piping and nylon strapping. This stand will comfortably support a thirteen-foot inflatable kayak but also works well for boats as short as eight feet. When folded up, it is about four inches thick.



Figure 1 - Kayak Work Stand Built of PVC Piping and Nylon Straps

Design Notes

Most work stands I saw on YouTube were only four feet long. A thirteen-foot low-pressure inflatable kayak just does not sit well on a four-foot-long stand. My personal twist on YouTube designs is to make the work stand seven feet long with midpoint support braces.

This stand is two frames constructed of seven-foot lengths of 1-1/2" Schedule 40 PVC pipe, with three-foot risers. One frame is just slightly shorter than the other, so it fits inside the longer frame. Although the frames are three-foot tall, the actual working height is controlled by the spread width. The spread width is controlled by the length of nylon straps.

Boating Hacks: A Kayak Work Stand

I could have used wood inside the pipe as reinforcement instead of the center braces. But that would add weight and extra expense over a little more PVC pipe.

Boating Hacks: A Kayak Work Stand

Layout

The center braces are 1" Schedule 40 PVC. I could have used 1-1/2" PVC for the braces, but I liked the slimmer 1" look. Plus, I happened to find 1-1/2" to 1" T-adapters while I was shopping and thought they looked cool.

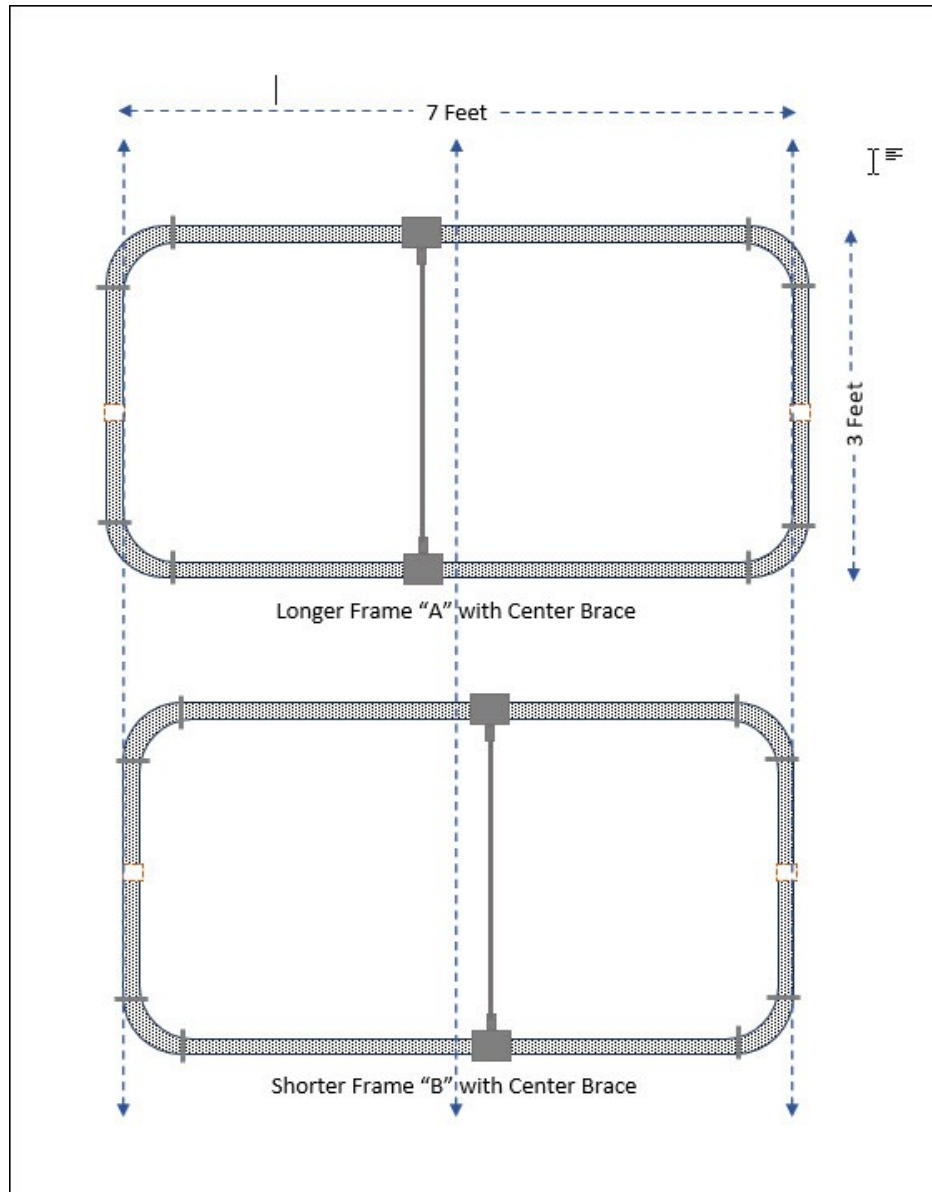

Figure 2 - Layout of the Two Frames, Before Interlacing the Center Braces

The only tricky part of construction is to interlace the center braces through the inner and outer frame.

Boating Hacks: A Kayak Work Stand

Pivot Bolts

I used two 3/8" x 5" galvanized bolts with galvanized nuts and washers to hold the frames together. This creates pivot points so the two frames will fold together when not in use. Larger bolts would also work, but I would not recommend using anything smaller. These bolts support the weight of the stand and kayak, so need to be strong.



Figure 3 - Detail of Pivot Bolts Through the PVC Pipe

Nylon Straps

I used one-inch-wide nylon strapping to connect the two frames and create support for the kayak. The length of the straps decides the width of the open stand, and the top straps provide the support for your kayak. After some trial-and-error, I settled on four upper straps and one on the bottom. The top straps, one at each end and two in the middle, work well to support all my kayaks. They are attached to the PVC using self-drilling hex-head screws with integral washers.

Boating Hacks: A Kayak Work Stand



Figure 4 - View Showing the Nylon Straps and Detail of Self-Drilling Screws

The bottom strap is important to maintain the working stand's width. I discovered that the top straps would sag under weight of a kayak, which messes with the stand's height. As the width changes, the height changes. So, the lower strap sets the maximum width the stand can open.

Wrapping the strap around the PVC adds strength. If you were to just screw in the ends of the straps and pull across to the opposite side, you could quickly tear out the strap. By wrapping it

Boating Hacks: A Kayak Work Stand

around the pipe at least once, as you put tension on the strap it jams the inner level of strapping tighter against the PVC.

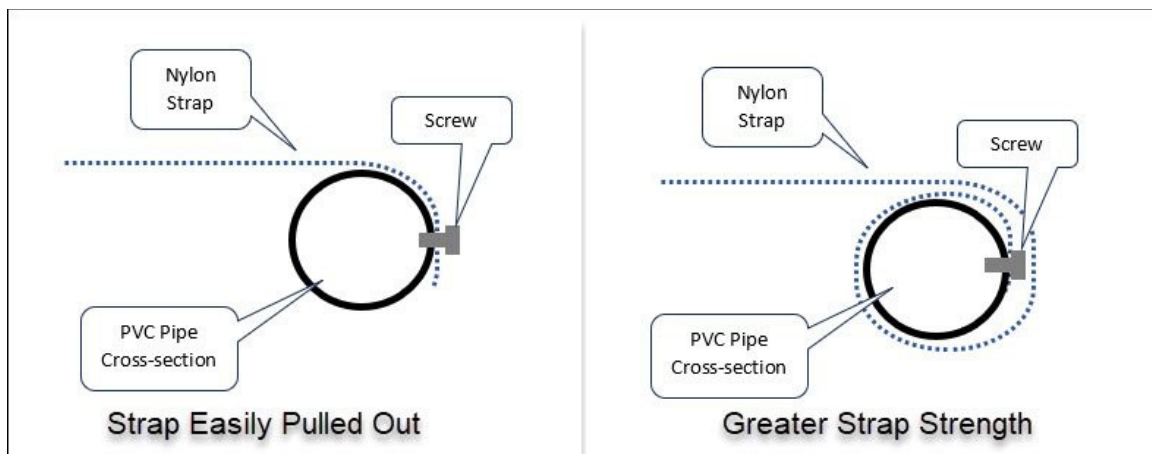

Illustration 1: Comparison of Attaching Nylon Straps

Tools

- Small hand saw. A backsaw with miter box is best.
- Sandpaper, 220 grit or finer.
- Electric drill with 3/8" diameter drill bit.
- Two wrenches, used for the 3/8" bolts and nuts.
- Tape measure.
- Screwdriver with hex socket for the self-drilling screws. An electric screwdriver is best.

Materials

- Four: Ten-foot lengths of 1-1/2" PVC Schedule 40 Pipe
- One: Ten-Foot Length of 1" PVC Schedule 40 Pipe
- Eight: 1-1/2" PVC Schedule 40 90 Degree Pipe Elbows
- Four: 1-1/2" to 1" PVC Schedule 40 "T" Connectors
- Seventeen feet: One-inch-wide nylon strapping (minimum length needed)
- Ten: Self-Drilling Hex Head Screws w/Washer, #8 x 9/16"
- Two: 3/8-in x 5-in Galvanized Coarse Thread Hex Bolts
- Two: 3/8-in x 16 Galvanized Steel Hex Nuts
- Two: 3/8" Galvanized Standard Split Washers
- Six: 3/8" Galvanized Standard Flat Washers
- One: Kit of PVC Cement and Primer.

Boating Hacks: A Kayak Work Stand

Assembly

This project should take about: 2 hours.

1. Creating the Short Pipe Sections

- Cut the ten-foot lengths of 1-1/2" pipe into seven-foot / three-foot lengths. Be sure to clean the cut ends with sandpaper so they will fit into the PVC elbows.
- Using a 3/8" drill bit, carefully drill matching holes in the center of each piece of pipe. These holes are used for the pivot bolts, so it is important to drill these holes through the middle of the pipe.

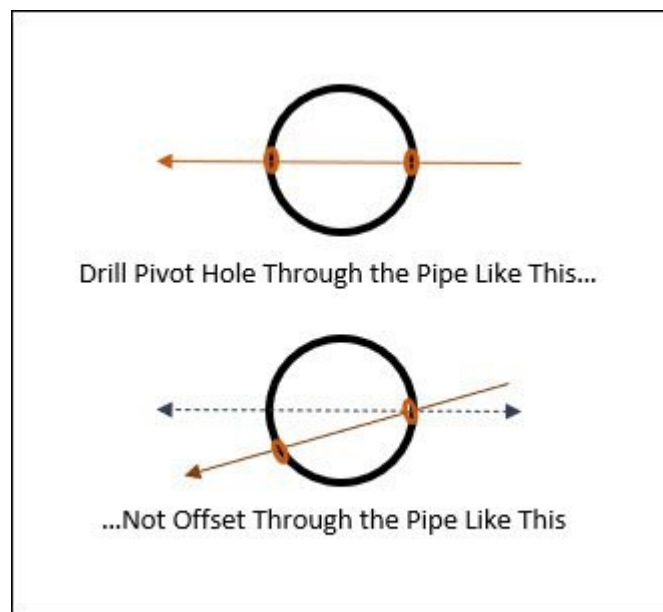

Figure 5 - Figure 6 - Detail of Drilling Pivot Holes

2. Gluing up Frame "A"

- Take two seven-foot lengths of pipe, two of the three-foot sections previously drilled, and four 1-1/2" PVC elbows.
- Glue these pieces together using the PVC primer and cement. Be careful to align the short side pieces so the center pivot holes align with each other.
- We will be cutting this frame to insert the center brace later.

Boating Hacks: A Kayak Work Stand

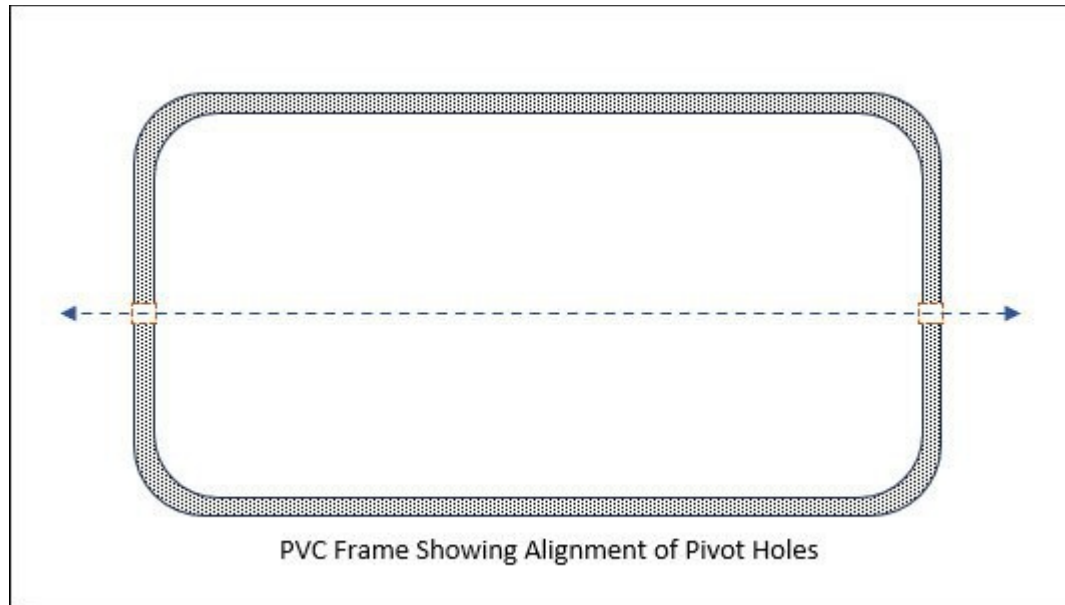

Figure 6 - PVC Frame Showing Alignment of Pivot Holes

3. Gluing up Frame "B"

- Take the two remaining seven-foot lengths of PVC pipe and cut three inches off one end of each pipe. Be sure to clean the cut ends with sandpaper so they will fit into the PVC elbows.
- Take the two remaining three-foot pieces of drilled pipe, and four 1-1/2" elbows. Glue up the frame, again being sure that the center pivot holes align with each other.

4. Inserting the Center Braces

- The center braces are offset and interlaced into the frames. You will add the brace to short Frame "B" first, then to the longer Frame "A."

Boating Hacks: A Kayak Work Stand

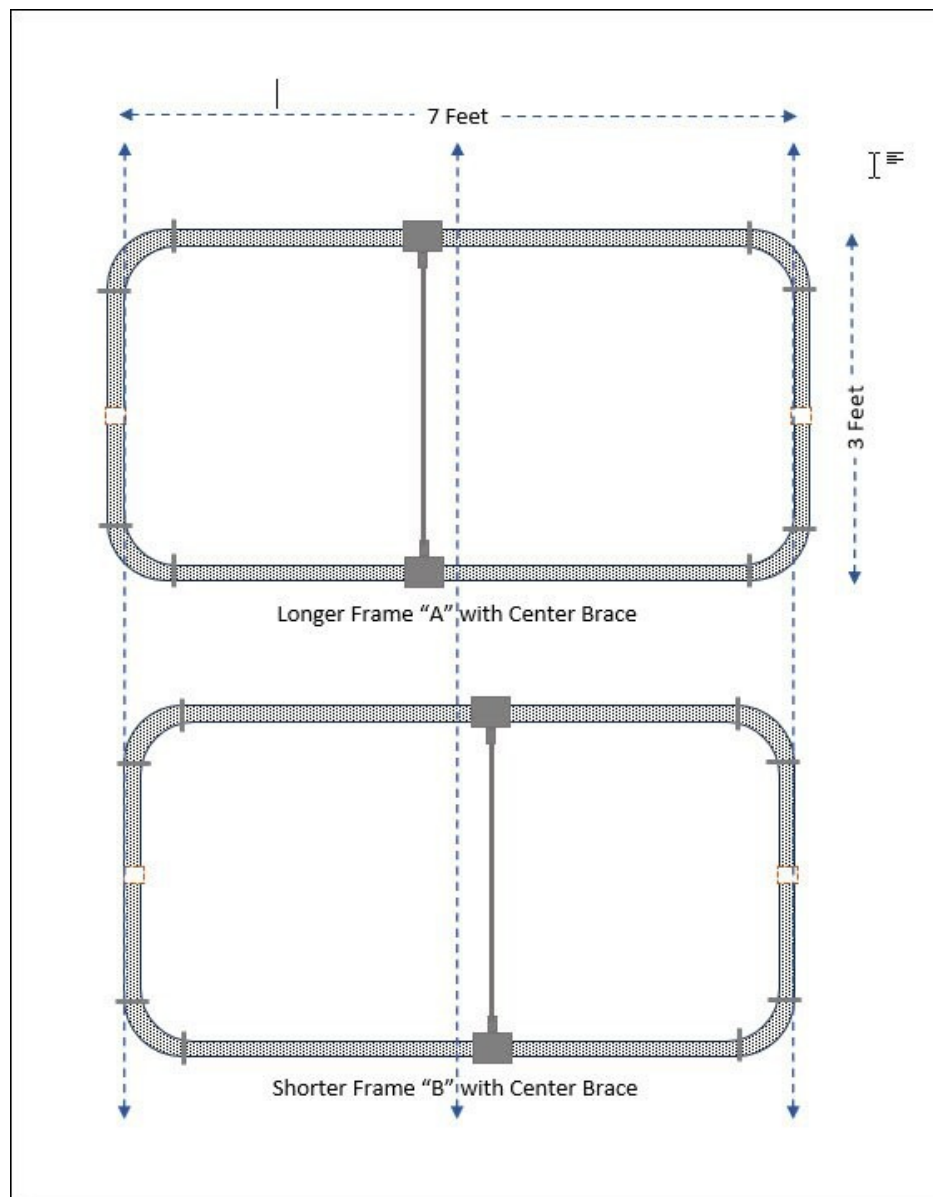

Figure 7 - Two Frames Showing Center Brace Alignment

5. Inserting Center Brace into Frame "B"

- Cut the ten-foot piece of 1" PVC pipe into two three-foot sections. Be sure to clean the cut ends with sandpaper so they will fit into the PVC "T" section.
- On Frame "B," along both long spans, measure 44" from the left end of the PVC Pipe (where it terminates inside the elbow).
- Cut the PVC pipe at this measurement. Be sure to clean the cut ends with sandpaper so they will fit into the PVC "T" sections.

Boating Hacks: A Kayak Work Stand

- Glue the 1-1/2" – 1" "T" fittings into one section of the frame. Be sure to keep the 1" ends aligned with each other, so the 1" PVC pipe will fit.

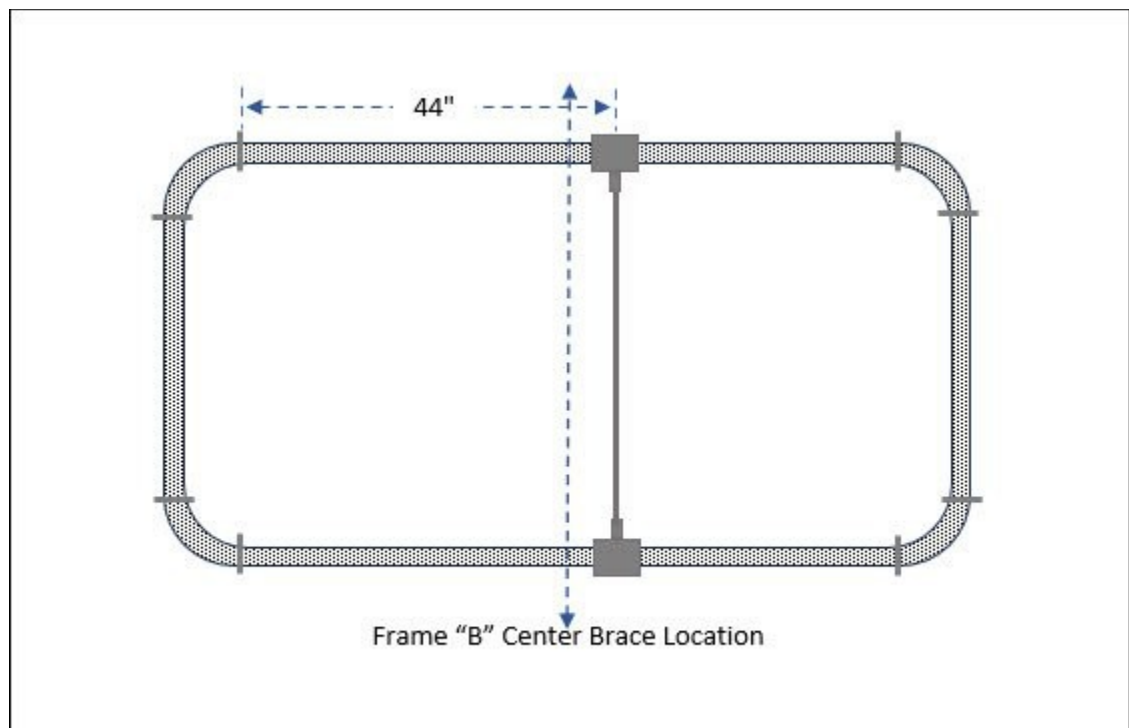

Figure 8 - Frame B Center brace Alignment

- Now glue one piece of 1" PVC into the open "T" ends. You will need to spread the 1-1/2" PVC slightly to fit.
- Once you have fitted the 1" PVC section into the "T" section, glue the other frame half into the open "T" fittings.
- This completes assembly of Frame "B".

6. Inserting Center Brace into Frame "A"

Boating Hacks: A Kayak Work Stand

- You will be using the other three-foot piece of 1" PVC pipe.
- On Frame "A," along both long spans, measure 41" from the left end of the PVC Pipe (where it terminates inside the elbow).

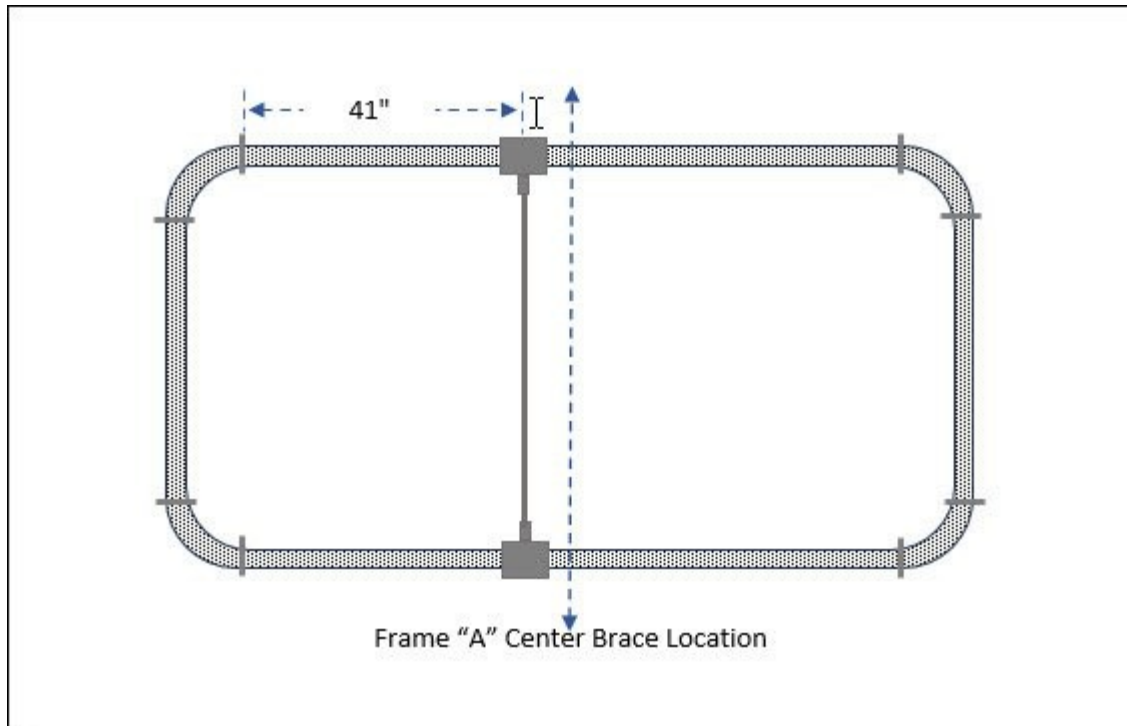

Figure 9 - Frame A Center Brace Alignment

- Cut the PVC pipe at this measurement. Be sure to clean the cut ends with sandpaper so they will fit into the PVC "T" sections.
- Glue the 1-1/2" – 1" "T" fittings into one section of the frame. Be sure to keep the 1" ends aligned with each other, so the 1" PVC pipe will fit.
- ** Now Comes the tricky part. **
- Glue one end of the 1" PVC brace into the top open "T" fitting.
- Place this section on top of the completed frame "B", so the left sides align. Slide Frame "A" down so the bottom overhangs Frame "B".
- Slide the bottom end of the center brace under Frame "B", then glue into the Frame "A" "T" fitting.
- Once you've fitted the 1" PVC section into the "T" section, glue the other frame half into the open "T" fittings.
- At this point, the two frames will be interlaced.

7. Installing the Pivot Bolts

Boating Hacks: A Kayak Work Stand

- Align the two Frames so the pivot holes at each end align.
- Put a flat washer on one of the pivot bolts so it's pushed up against the bolt head.
- Insert the bolt through the longer Frame "A" hole.
- Slide a flat washer over the bolt between Frame "A" and Frame "B".
- Push the bolt all the way through the pivot hole of Frame "B". Slip on another flat washer, then a lock washer, then a nut.

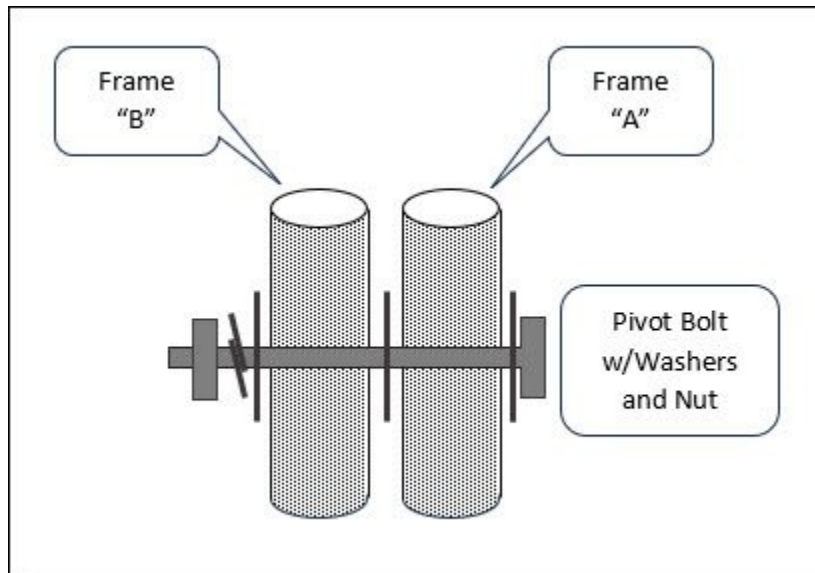

Figure 10 - Detail of Pivot Bolt Installation

- Repeat on the pivot hole on opposite side of the workstation.
- Tighten the nuts on both pivot bolts until snug. You want to leave them just loose enough so the two frames can pivot freely.

8. Measure and Cut Nylon Straps

Boating Hacks: A Kayak Work Stand

– The width (and height) of your work stand depends upon the length of the nylon straps. You want your work stand to be wide enough so your kayak(s) will fit between the PVC piping. If the kayaks sit on top, they will tend to slide off the stand while you are attempting to do stuff to them. Note that the wider you make your stand, the lower to the ground it will end up.

- - I set my width at 27" inches, which is a decent width for most recreational kayaks. At this width, the stand height is about 27" which is great for me. A little wider might be better, but then the boat will sit lower to the ground.

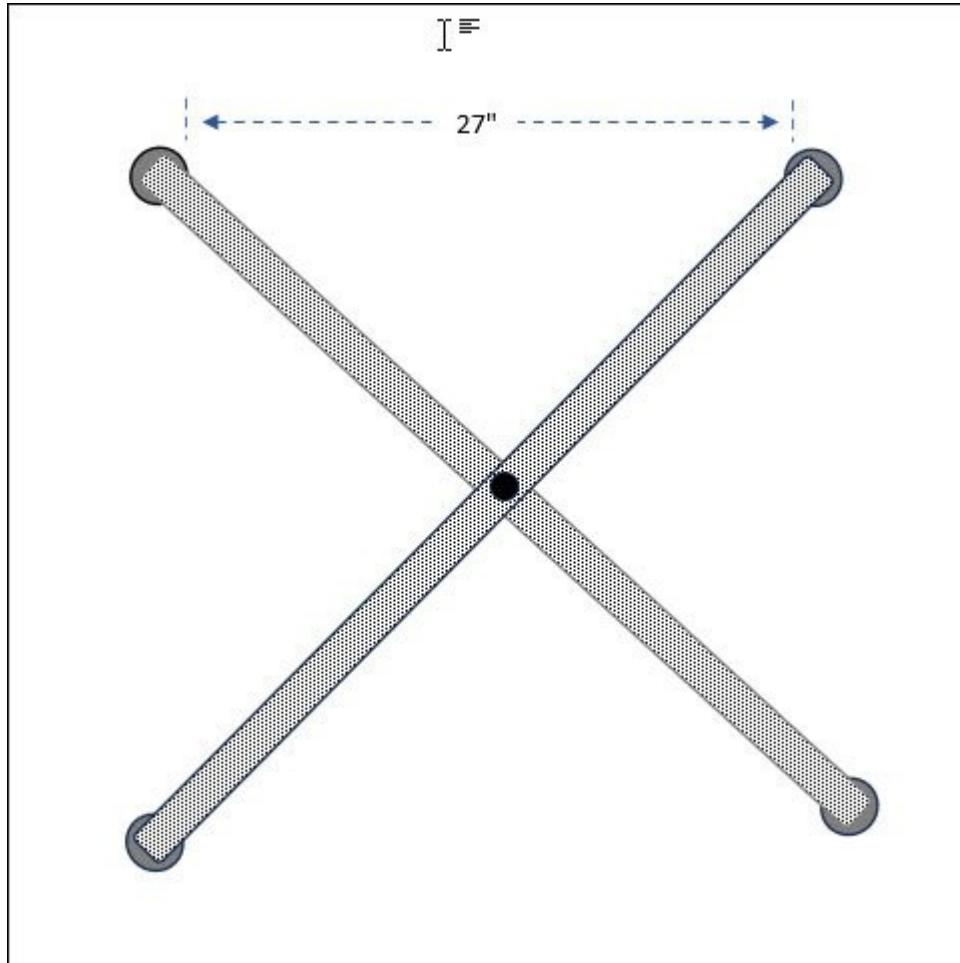

Figure 11 - End View of Work Stand Showing Spread Width

- Whatever width you choose, you will need to add at least an extra 12" length to the nylon straps to allow for wrapping them around both sides of the frames.
- Once you've determined the length, cut your one-inch-wide nylon strapping into five equal lengths. Be sure to heat-seal the cut edges so they do not unravel.

Boating Hacks: A Kayak Work Stand

9. Attach Top Nylon Straps

- On the top pipes, mark four points on the outside of the PVC, aligned across each frame. I placed straps at the junction of the 1-1/2" elbows at end, and two in the middle just past the "T" fittings of the center braces. This seems to work out well and provides adequate support for my kayaks.
- Place one end of a nylon strap against the PVC pipe and run a self-drilling screw through the strap and pipe until the screw is snug.

Boating Hacks: A Kayak Work Stand



Figure 12 - Detail of Nylon Strap Installation

- Wrap the strap around the pipe once, then run it across to the opposite side of the stand.
- Keep the two frames close together so there is adequate slack in the strap. Wrap the strap around the pipe once, starting at the top, and finish with the end of the strap over your location mark.
- Run a self-drilling screw through the strap and pipe until the screw is snug. Repeat with the remaining three straps.

Boating Hacks: A Kayak Work Stand

10. Attach Bottom Nylon Strap

– Turn the work stand upside down.



Figure 13 - Detail of Bottom Strap

– Mark mounting locations for the single bottom strap. I mounted mine in the space between the center support brace “T” fittings.

Boating Hacks: A Kayak Work Stand

- Attach this strap the same way you attached the upper straps.
- Turn the frame right side up, and you are done!

Your kayak work stand is finished!